

BCW22

Bosch Connected World 2022

The leading event on AIoT and digital transformation
on-site in Berlin or **online** from wherever you are.

Additional options for hybrid exhibitors



Bosch ConnectedWorld 2022

Additional options

Welcome to the BCW exhibition!

Your booth – either on-site and/or online – will be the central point of contact for all event attendees. To help you get the most out of your presence at the event, increase attention and create a memorable experience, we've listed some additional options for you.

Choose your area of interest below and see the corresponding options:

- ▶ **Drive traffic to your on-site booth**
- ▶ **Boost your online presence**
- ▶ **Create marketing content**
- ▶ **Enhance your customer and partner relationship**
- ▶ **Facilitate your on-site booth organization**

See details in this slide deck.



Bosch ConnectedWorld 2022

Choose the right option for your targets

Drive traffic to your on-site booth

Slides 4-12

- ▶ Live-stream your presentation from your on-site booth
- ▶ Become a stop on the guided exhibition tour
- ▶ Refreshments at your booth
- ▶ Flexible indoor branding
- ▶ Outdoor branding at BCW
- ▶ Brand a catering area

Boost your online presence

Slides 13-15

- ▶ Extend your exhibitor presentations
- ▶ Add more content to your booth

Create marketing content

Slides 16-21

- ▶ Photo shoot
- ▶ Video team

Enhance your customer and partner relationship

Slides 22-27

- ▶ Invite your customers
- ▶ Private meeting room
- ▶ Private customer event
- ▶ Event at your booth

Facilitate your on-site booth organization

Slides 28-31

- ▶ Additional on-site booth equipment
- ▶ Storage space & lockers
- ▶ Catering for your booth staff during set-up and tear down

Drive traffic
to your
on-site booth

Drive traffic to your on-site booth

Live-stream your presentation

- ▶ Move your included exhibitor presentations from the virtual world to your on-site booth.
- ▶ Use your on-site exhibits and showcases for your exhibitor presentations and answer live audience questions on-site and online.

Option 1: Hardware + support

- ▶ Ready-to-use production equipment for 2 hours (2 sessions): High quality webcam incl. tripod, configured laptop, wireless microphone incl. transmitter
- ▶ Technical support on-demand for set-up

Price: **EUR 550 net** (for 2 hours)

[Book in MyBCW Partner Portal](#)

Option 2: Professional camera team

- ▶ Production team with camera, sound and streaming equipment
- ▶ Before: camera team briefing
- ▶ During: Execution of 30-minutes live-stream
- ▶ After: Recording and publishing at BCW.online

Price: **EUR 2,400 net** (per session)

[Book in MyBCW Partner Portal](#)



Drive traffic to your on-site booth

Become part of the exhibition tour

- ▶ Become a stop of the guided exhibition tour! The tour is produced on-site, live-streamed for the online audience, recorded and published on BCW.online.
- ▶ A tour lasts approx. one hour and includes approx. five exhibitor booths. All tours will take place twice (once on the first day and once on the second day of BCW2022).
- ▶ Included in this offer:
 - ▶ 2 x 10 min slot (6 min presentation + 4 min Q&A) in an exhibition tour
 - ▶ Online and offline promotion of the tours in the agenda
 - ▶ Production, live-streaming, recording and publishing on BCW.online
- ▶ The booking is on a first-come first-serve basis.

Price: **EUR 3,300 net**

Booking deadline: September 30, 2022

Book in MyBCW Partner Portal



Drive traffic to your on-site booth

Refreshments at your booth

- ▶ Serving refreshments at your booth is always a good hook to engage with prospects.
- ▶ You can choose between having refreshments, a coffee station or snacks at your booth.
- ▶ Included in this offer:
 - ▶ Coordination with the caterer
 - ▶ Set-up and dismantling
 - ▶ Daily delivery
- ▶ Excluded:
 - ▶ Catering staff
- ▶ The pricing depends on the amount and type of refreshments. Please contact us to get your individual offer.

Price: [on request](#)

Booking deadline: October 7, 2022

[Email to the BCW team](#)



Drive traffic to your on-site booth

Flexible indoor branding

- ▶ Use flexible illumination columns to showcase your solutions and drive traffic to your booth.
- ▶ The columns can be placed throughout the venue. Placement requests will be honored on a first-come-first-serve basis.
- ▶ Included in this offer:
 - ▶ Production (print data to be provided by you)
 - ▶ Assembly & installation
 - ▶ Electricity
- ▶ Deadline for the design submission: September 9, 2021

Price: **EUR 1,500 net**

Booking deadline: September 2, 2021

Book in MyBCW Partner Portal

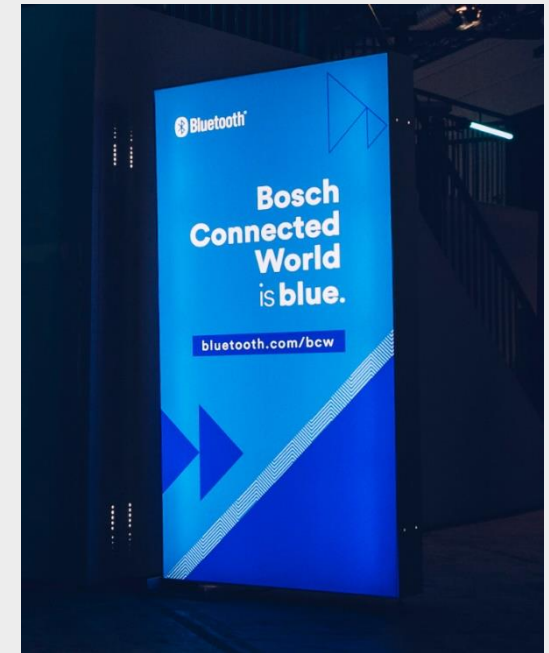
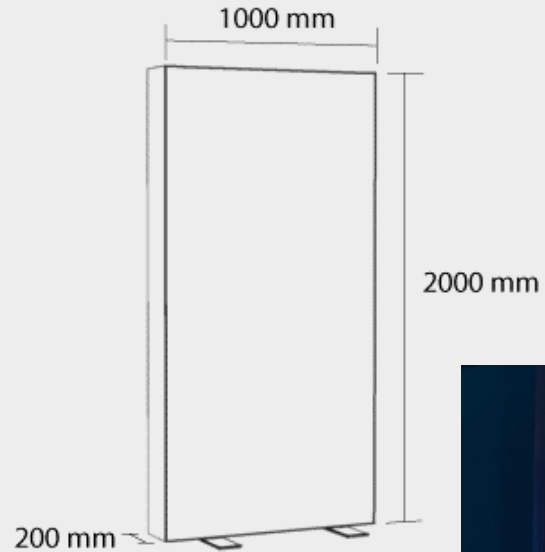

Drive traffic to your on-site booth

Outdoor branding I

- ▶ To drive traffic to your booth, use an inflatable banner that will be placed in the courtyard. The banner is located at the main entrance of the venue and is visible to all visitors on-site.
- ▶ Banner size: 25sqm
- ▶ Included in this offer:
 - ▶ Production (print data to be provided by client)
 - ▶ Mounting
 - ▶ Dismantling
- ▶ There are only two available banners on a first-come first-serve basis.
- ▶ Deadline for the design submission: September 30, 2021

Price: **EUR 4,900 net**

Booking deadline: September 23, 2021

Book in MyBCW Partner Portal

Located:

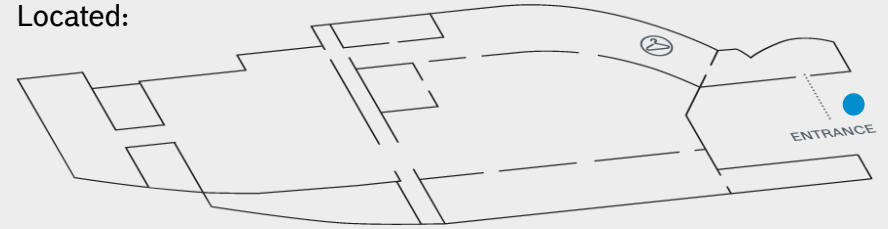

Drive traffic to your on-site booth

Outdoor branding II

- ▶ To drive traffic to your booth, use eye-level advertising located in the courtyard. The banner is located at the entrance of the venue and will be seen by all visitors.
- ▶ Banner size: 9sqm
- ▶ Included in this offer:
 - ▶ Production (print data to be provided by you)
 - ▶ Mounting
 - ▶ Dismantling
- ▶ There are only two available banners on a first-come first-serve basis.
- ▶ Deadline for the design submission: September 30, 2021

Price: **EUR 2,500 net**

Booking deadline: September 23, 2021

Book in MyBCW Partner Portal

Located:

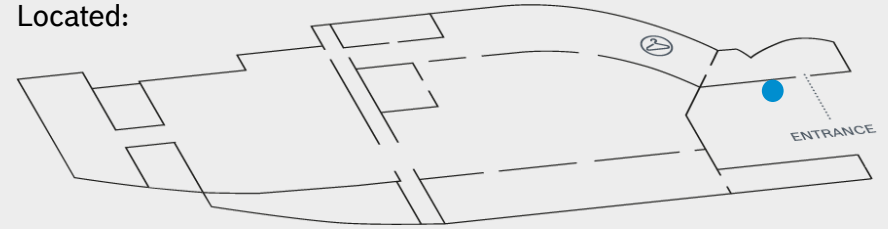

Drive traffic to your on-site booth

Outdoor branding III

- ▶ To present your solutions to BCW attendees coming from the metro station or passing by the venue, you can use an outdoor advertisement on the street in front of the venue.
- ▶ Banner size: 9sqm
- ▶ Included in this offer:
 - ▶ Production (print data to be provided by you)
 - ▶ Mounting
 - ▶ Dismantling
- ▶ There are only two available banners on a first-come first-serve basis.
- ▶ Deadline for the design submission: September 30, 2021

Price: **EUR 2,900 net**

Booking deadline: September 23, 2021

[Book in MyBCW Partner Portal](#)

Located:

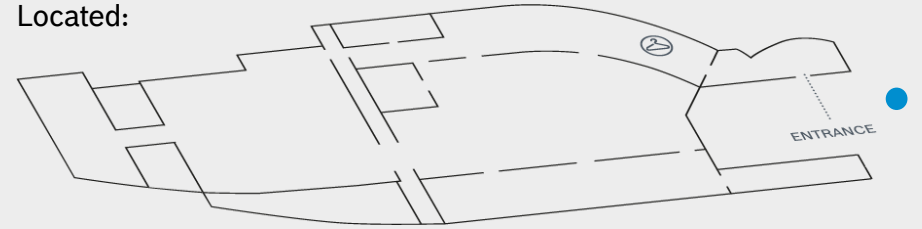

Drive traffic to your booth

Brand a catering area

- ▶ Place your branding on and around the food and beverage stations.
- ▶ Ideas can include:
 - ▶ Logo placement in a dedicated catering zone
 - ▶ Branded napkins, muffins, desert, water bottles etc.
- ▶ Is this something for you? Let us know and we'll work on a concept with you!

Price: [on request](#)

Booking deadline: September 30, 2021

Email to the BCW team



Boost your
online presence

Boost your online presence Extend your exhibitor presentations

- ▶ Get an additional 30 min. exhibitor presentations to either extend your existing exhibitor presentations or to have an additional presentation slot.
- ▶ Date & time: the choice is yours
- ▶ Language: the choice is yours
- ▶ Topic: the choice is yours
- ▶ Max. number of participants 100
- ▶ Supported streaming providers: all external links can be included
- ▶ All additional presentation slots will be displayed in the agenda.

Price: **EUR 990 net** (per 30 min.)

Booking deadline: October 7, 2022

Book in MyBCW Partner Portal

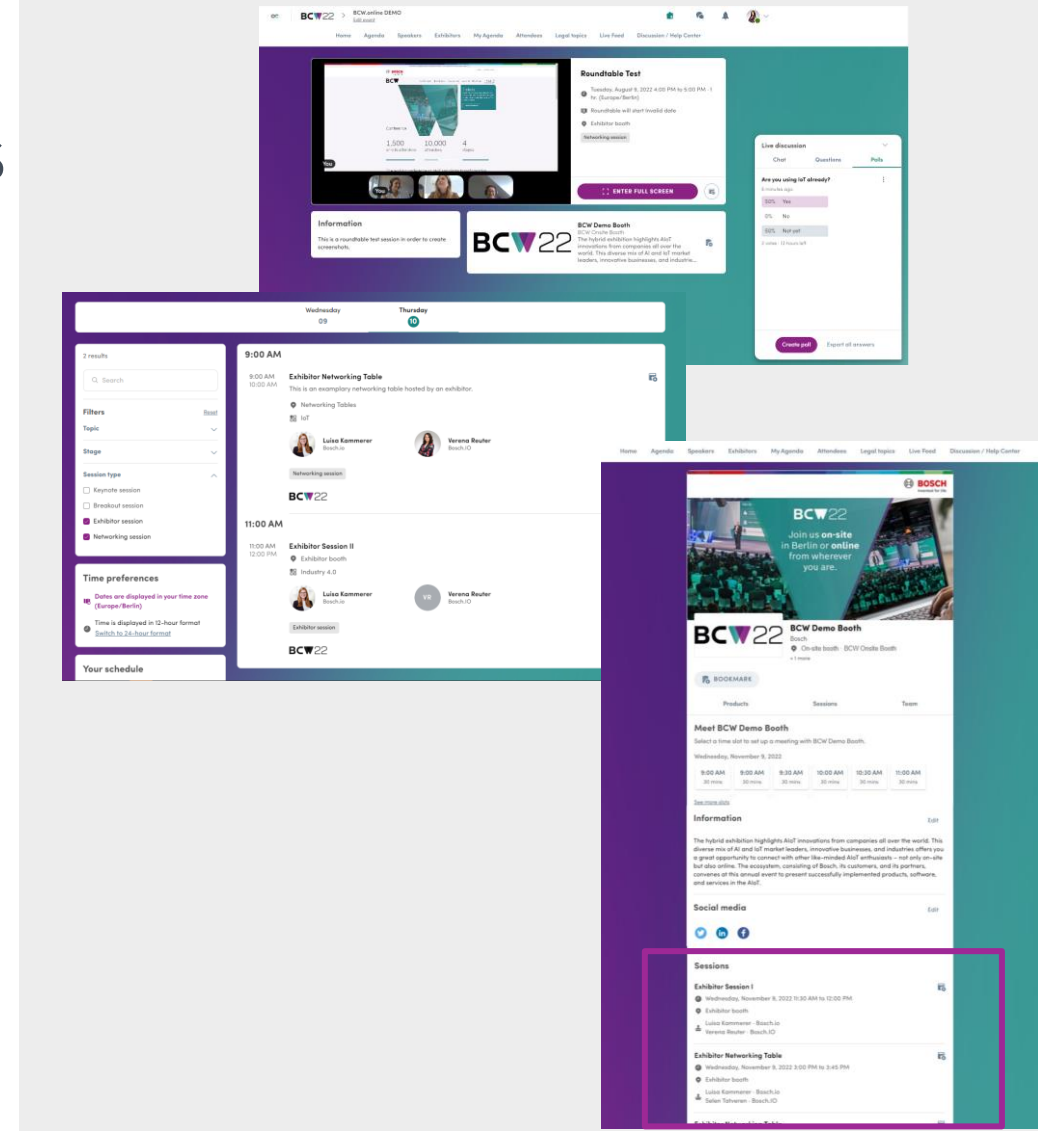

Boost your online presence

Add more content to your booth

- ▶ Present further products by booking an additional product page for your online booth.
- ▶ Features:
 - ▶ Text
 - ▶ Images
 - ▶ Links
- ▶ The price is per product page.
- ▶ This option can be booked a maximum of three times.

Price: **EUR 300 net**

Booking deadline: October 7, 2022

Email to the BCW team

The image shows a screenshot of the BCW22 online booth interface. The main content area displays the 'BCW Demo Booth' page, which includes a header with the event name and location, a 'BOOKMARK' button, and a 'Meet BCW Demo Booth' section with a meeting schedule for Wednesday, November 9, 2022. Below this is an 'Information' section with text about the hybrid exhibition, a 'Social media' section with icons for Twitter, LinkedIn, and Facebook, and a 'Contact details' section with a URL. At the bottom, there is a 'Products' section with two product cards: 'BCX' and 'The Exhibition'. A purple box highlights the 'Products' section. To the right, a separate window shows a detailed view of the 'BCX' product page, including a photo of people at a booth, a 'Products' section with three small images, and an 'ADD TO MY WISH LIST' button. Below this is an 'Information' section with text about the BCX product and a 'Product video' section with a YouTube link.

Create
marketing content

Create marketing content

On-site photo shoot

- ▶ Book a photographer for 45 min to shoot photos at a location of your choice at the event, e.g. your on-site booth, your speaker on stage etc.
- ▶ The photo shoot will be based on your briefing and requirements to fit your individual needs.
- ▶ Included in this offer:
 - ▶ Photo shoot (45 min)
 - ▶ Picture quality of 300dpi resolution
 - ▶ Unedited images
 - ▶ Total buy out of all pictures and rights
 - ▶ Delivery: one day after the photo shoot

Price: **EUR 590 net**

Booking deadline: October 7, 2022

Book in MyBCW Partner Portal



Create marketing content

On-site video shoot

- ▶ Book a professional camera team for one hour to film a showcase, demo, interviews, or any other content that you want to use for further marketing activities.
- ▶ Included in this offer:
 - ▶ Professional camera team (1 hour) filming max. 30 minutes
 - ▶ Post-editing team (max. 4 hours)
 - ▶ A ready-to-use video with opening and closing (duration max 3 minutes)
 - ▶ Delivery: two days after the event
- ▶ The following effort is necessary from your side:
 - ▶ Content input and briefing
 - ▶ Coordination and contact person on-site during the shooting
 - ▶ Final video approval with the post-editing team

Price: **EUR 2,700 net**

Booking deadline: October 7, 2022

Book in MyBCW Partner Portal



Create marketing content

On-site stage photo shoot

- ▶ Book a photographer for 45 min to shoot photos of your company's stage presence.
- ▶ The photo shoot will be based on your briefing and requirements to fit your individual needs.
- ▶ Included in this offer:
 - ▶ Photo shoot (45 min)
 - ▶ Picture quality of 300dpi resolution
 - ▶ Unedited images
 - ▶ Total buy out of all pictures and rights
 - ▶ Delivery: one day after the photo shoot
- ▶ Note: you only can purchase photo content showing representatives of your own company.

Price: **EUR 590 net**

Booking deadline: October 7, 2022

Email to the BCW team



Create marketing content

On-site stage video shoot (summary)

- ▶ Get a 3-minute video of your company's stage presence to share on social media, website, and internal channels.
- ▶ Included in this offer:
 - ▶ Filming of the relevant stage content with two cameras
 - ▶ A ready-to-use video with highlight sections of the speech, opening and closing (duration max. 3 minutes)
 - ▶ Delivery: two days after the event
- ▶ The following effort is necessary from your side:
 - ▶ Content input and briefing
 - ▶ Coordination and contact person on-site during the shooting
 - ▶ Final video approval with the post-editing team
- ▶ Note: you only can purchase the video content showing representatives of your own company.

Price: **EUR 2,200 net**

Booking deadline: October 7, 2022

Email to the BCW team



Create marketing content

On-site stage video shoot (full-length)

- ▶ Get the full-length video of your company's stage presence to share on social media, website, and internal channels.
- ▶ Included in this offer:
 - ▶ Filming of the relevant stage content with two cameras
 - ▶ A ready-to-use video of the entire speech with opening and closing (duration max. 20 minutes)
 - ▶ Delivery: two days after the event
- ▶ The following effort is necessary from your side:
 - ▶ Content input and briefing
 - ▶ Coordination and contact person on-site during the shooting
 - ▶ Final video approval with the post-editing team
- ▶ Note: you only can purchase the video content showing representatives of your own company.

Price: **EUR 1,500 net**

Booking deadline: October 7, 2022

Email to the BCW team



Enhance your customer
and partner relationship

Enhance your partnership Invite your customers

- ▶ Do you think your customers, partners, suppliers, and influencers would benefit of being part of BCW?
- ▶ We are delighted to offer you the **opportunity to invite members of your professional and social network** to join you at the event either on-site in Berlin or online from wherever they are **for an extended early bird rate**.
- ▶ You can choose between the following ticket options:
 - ▶ **On-site premium ticket (at your expense):** The customer is invited free of charge. You are taking over the costs of EUR 890 net.
 - ▶ **On-site premium ticket (reduced rate at customers expense):** Your network benefits from the extended early bird rate of EUR 890 net.
 - ▶ **Online premium ticket (at your expense):** The customer is invited free of charge. You are taking over the costs of EUR 190 net.
 - ▶ **Online premium ticket (reduced rate at customers expense):** Your network benefits from the extended early bird rate of EUR 190 net.
 - ▶ **Online freemium tickets** are free of charge, so no registration code is required

Book in MyBCW Partner Portal



Enhance your partnership

On-site booth event

- ▶ Do you have a special occasion that you want to celebrate with your customers and partners? Consider to book a booth event for an award ceremony, a contract signing, and other occasions.
- ▶ Included in this offer:
 - ▶ Catering (food, drinks, equipment, staff)
 - ▶ Photo shoot (45 min)
 - ▶ Set up & dismantling
 - ▶ Coordination and project management
- ▶ The pricing depends on the number of participants and type of catering. Price on request.

Price: **on request**

Booking deadline: October 7, 2022

Email to the BCW team



Enhance your partnership

Private meeting rooms

- ▶ We offer spaces for you to meet with your prospects or customers in a private meeting room.
- ▶ This private meeting room can be booked for a minimum of 45 minutes and a maximum of 3 hours.
- ▶ Included in this offer:
 - ▶ 25 sqm room with a capacity up to 8 pax
 - ▶ 1 monitor on a stand
 - ▶ 2 tables with 8 chairs
 - ▶ 1 flip chart
 - ▶ soft drinks
- ▶ The meeting rooms will be allocated on a first-come-first-serve basis.

Price: **EUR 490 net (45 min)**

[Email to the BCW team](#)



Enhance your partnership

Private customer event

- ▶ We offer large loft rooms to hold a customer event or a separate presentation in a larger group.
- ▶ The meeting room can be booked for a minimum of 45 minutes.
- ▶ Included in this offer:
 - ▶ Capacity: up to 60 pax seated (max. up to 120 pax standing)
 - ▶ Tables/high tables with chairs
 - ▶ 1 flip chart
 - ▶ Projector & audio equipment
 - ▶ Soft drinks
- ▶ The meeting rooms will be allocated on a first-come-first-serve basis.

Price: **EUR 690 net (45 min)**

Email to the BCW team

Located:

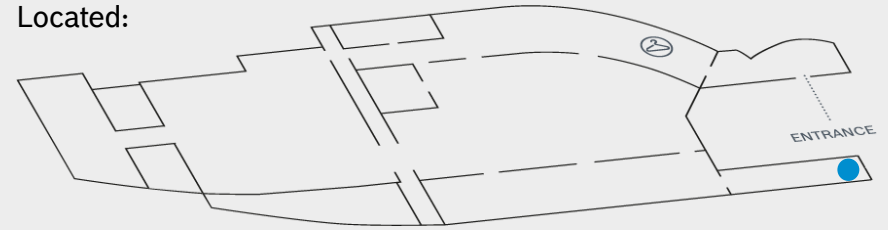

Enhance your partnership Customer event with catering

- ▶ We offer large loft rooms to hold a customer event with catering options for breakfast, lunch, or dinner.
- ▶ The meeting room can be booked for a minimum of 45 minutes on a first-come-first-serve basis.
- ▶ The maximum capacity is 60 pax seated and 120 pax standing.
- ▶ Interested? Please contact us with your meeting requirements and we will send you an individual offer.

Price: **on request**

Booking deadline: October 7, 2022

Email to the BCW team

Located:

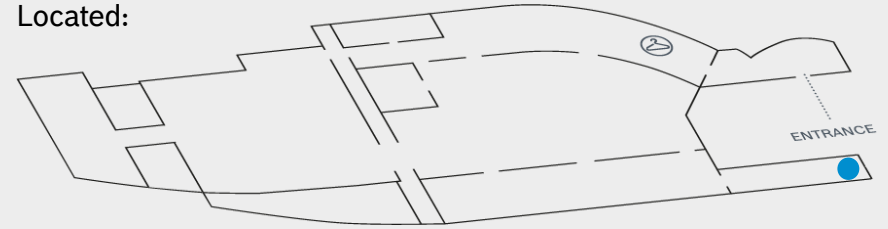

Facilitate your
on-site booth
organization

Facilitate your booth organization

Additional on-site booth equipment

- ▶ In addition to the standard booth equipment, you can get additional furniture or technical equipment to customize your space.
- ▶ To get detailed information on the available items, including pictures, download the catalogue in the MyBCW Partner Portal on the tab “Additional options”*.

*For any orders after October 7, 2022, an extra fee of 25% will be charged to your order. Changes later than October 21, 2022, are not possible.

Price: [see catalogue](#)

Booking deadline: October 7, 2022

Book in MyBCW Partner Portal



Facilitate your booth organization

On-site storage space

- ▶ Do you need additional storage space for marketing or packaging materials during the event? We have you covered!
- ▶ We offer two options to store your materials:

Large storage space

- ▶ Perfect fit for transport boxes or other huge packing materials
- ▶ Access during set-up and tear-down; no access during the event
- ▶ Price per cubic meter: EUR 120 net

Book in MyBCW Partner Portal

Lockers

- ▶ Perfect fit for smaller marketing materials and devices
- ▶ Secured with individual keys
- ▶ All-time access
- ▶ Located next to the wardrobe
- ▶ Size: 40x40x40cm
- ▶ Price per locker during the entire event: EUR 100 EUR

Book in MyBCW Partner Portal



Facilitate your booth organization

Catering for your on-site booth staff during set-up and tear down

- ▶ For the time before the event and after the event, meaning setup and dismantling, we offer crew catering.
- ▶ You can select between several options including breakfast, lunch, and dinner.
- ▶ We will send detailed information on the pricing and the options latest by January.



Contact

Contact

Exhibition management



Solveig Gaida
Manger IoT Marketing,
Exhibitor relations
Bosch.IO

[Send email](#)



BCW22

Bosch Connected World 2022

See you **on-site** in Berlin
or **online** from wherever you are

